

4

3

2

1

NOTES: UNLESS OTHERWISE SPECIFIED

- 1 INTERPRET DRAWING IN ACCORDANCE WITH ANIS Y14.5-1994
- 2 PARTS TO BE PACKAGED IN TAPE & REEL PER EIA STD-481
- 3 PICK-UP TAB DEFLECTS UPON INSERTION OF THE SHIELD.

PART NUMBER BREAKDOWN

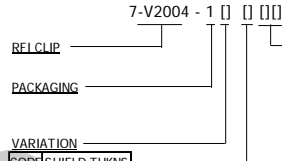

PLATING CODE

AA= PREPLATED .000120 [0.00305] MIN Sn/Pb
OVER .000050 [0.00127] MIN Ni
TT= PREPLATED .000120 [0.00305] MIN MATTE
Sn OVER .000050 [0.00127] MIN Ni

MAT'L DESIGNATION

CODE	MATERIAL
5	COPPER ALLOY
0	STAINLESS STEEL

VARIATION

CODE	SHIELD THKNS
1	.014±.002 [0.36±0.05]
2	.019±.002 [0.48±0.05]

REV	REVISION RECORD	ECN	BY	APVD	DATE
F	CHANGE PAD SIZE	16072	JOE	JB	01/14/99
G	PER EWR100642	500811	TM	JB	08/29/00
H	CHG QTY PER REEL TO 2,000	501002	JB	JB	10/18/00
J	ADDED "TT" PER EWR103508	503111	BILL	JB	1/20/2004
K	ADDED NEW PART PER EWR103913	503390	BILL	JB	6/3/2004
L	REVISE P/N TABLE EWR105512	505010	HR	PVB	6/20/2007
M	ADD NEW MAT'L PER EWR105673	505247	HR	PVB	1/15/2008
N	REVISE NOTE PER EWR106134	505531	HR	PVB	9/8/2008
P	ADDED .155 MIN SHIELD HEIGHT	505554	DJA	HR	9/24/2008

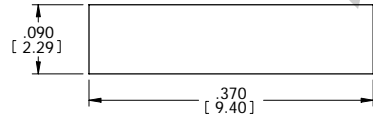

RECOMMENDED PAD SIZE

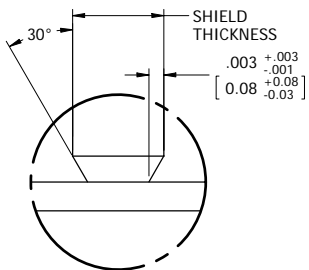
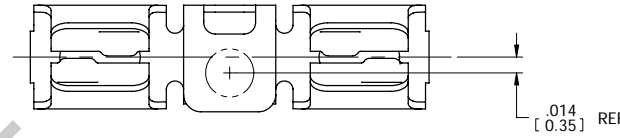

DETAIL A
EDGE FINISH
RECOMMENDATION

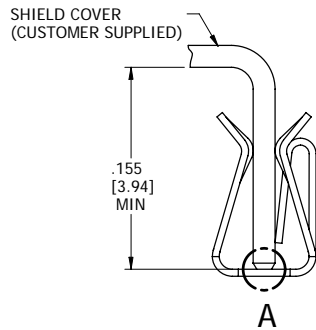

APPLICATION VIEW

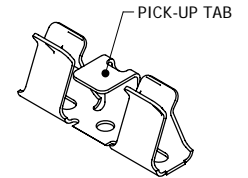
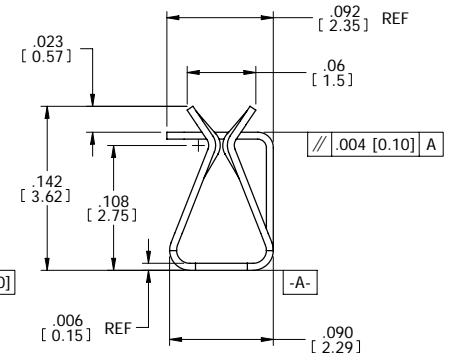
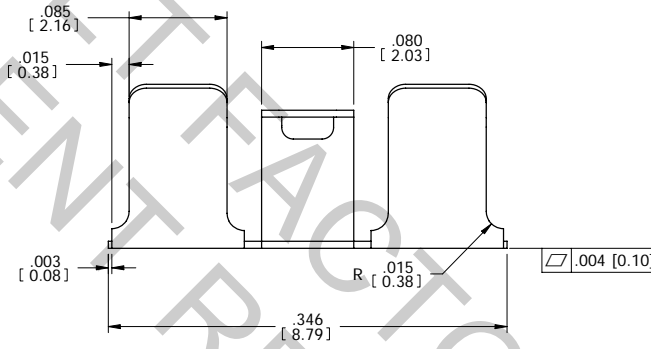

CUSTOMER DRAWING

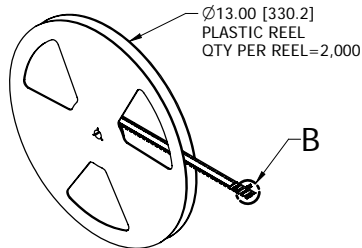

TAPE & REEL PACKAGING

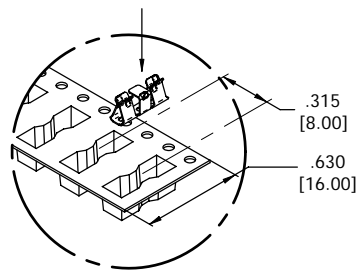

DETAIL B

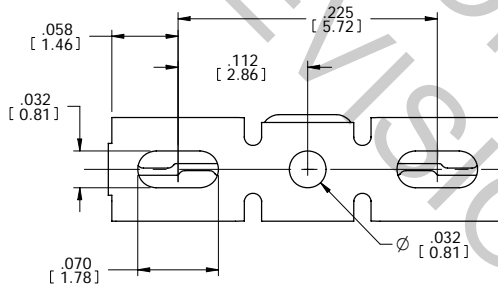

The drawing and the information set forth hereon are the property of Autosplice, Inc. and are to be held in trust and confidence. Publication, disclosure, or use for any purpose not expressly authorizing in writing by Autosplice, Inc. is prohibited.

MATERIAL:
FINISH:

TOLERANCES UNLESS OTHERWISE SPECIFIED DIMENSIONS IN INCHES (mm)		autosplice Autosplice, Inc. 10121 Barnes Canyon Rd. San Diego, CA 92121-2725 858.535.0077	
DECIMAL: .XX = ± .02 [XX] = ± [0.5] XXX = ± .010 [XXX] = ± [0.25]	ANGULAR: ± 2°	DATE: 3/20/97	DATE: 3/20/97
TITLE: SMT MIDI RFI CLIP		ENGINEERED BY: JOE	DATE: 3/20/97
SIZE: C	DESIGN NO: OAE89	DATE: 3/20/97	REVISION: P
DRAWING NUMBER: C7-V2004-1		MODEL NO: 7-v2004.ppt	
SHEET 121		SHEET 1 OF 1	

4

3

2

1